



# Clean Pond Machine

7000 • 10000  
13000 • 16000



[www.blagdonwatergardening.co.uk](http://www.blagdonwatergardening.co.uk)



Blagdon Water Gardening



# Clean Pond Machine

7000 • 10000  
13000 • 16000

**Congratulations on buying a Blagdon Clean Pond Machine filtration system.** Manufactured with advanced filtration technology to create a clean and healthy pond for you fish.

When used in combination with Blagdon Clean Pond Pods, this filter has been designed to minimise maintenance, and make necessary maintenance easier.

**IMPORTANT:** PLEASE ATTACH PROOF OF PURCHASE TO THIS MANUAL AND KEEP IN A SAFE PLACE.

# CONTENTS

## GETTING YOU KNOW YOUR FILTER

Parts diagram .....	2
Parts table .....	3
Technical specifications .....	4

## INSTALLATION

Electrical installation .....	5
Locating the filter .....	6
Connecting to your pump .....	7
Connecting the inlet/outlet hoses .....	7
UVC Maintenance .....	8
Replacing the UVC bulb .....	9

## CLEANING AND MAINTENANCE

Normal running .....	10
Routine maintenance .....	10
Cleaning your filter .....	11
Winter storage .....	12
Annual maintenance .....	12
Replacing Filter Media .....	12
Disassembling/reassembling your Clean Pond Machine .....	13





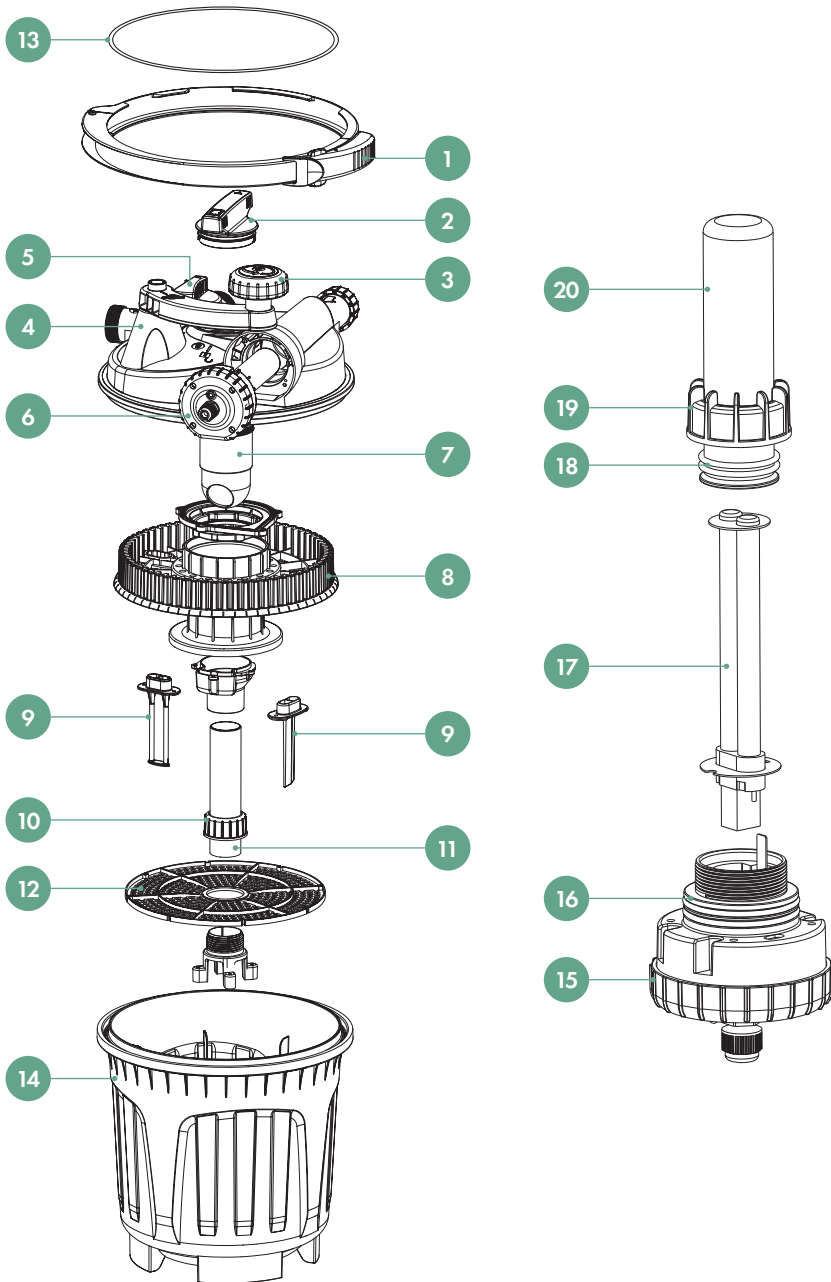

## TROUBLESHOOTING

Filter leaks .....	14
Cloudy/brown water .....	14
UVC leaks .....	14
Low/no flow from filter .....	14
Green water .....	15
Faults - problems procedure .....	16
Guarantee .....	16
Environment friendly disposal .....	16

## GETTING TO KNOW YOUR FILTER









## GETTING TO KNOW YOUR FILTER





	Part Description	Spares code
1	Filter Lid Clasp	1057660
2	Dosing Chamber Cap 	-
3	Cleaning Handle Knob 	1057677
4	Filter Head Unit	-
5	Flow Diverter Valve	-
6	Complete UVC Unit 	As Parts 1
7	Dosing Chamber	-
8	Head Unit Filter Grill	-
9	Filter Cleaning Blades	-
10	Downpipe Locking Nut	-
11	Downpipe	-
12	Cannister Filter Grill 	-
13	Filter Head Unit Gasket (O-ring)	1057684
14	Filter Cannister	-
15	UVC End Cap and Electrics	7000: 1057691 10000: 1057707 13000: 1057714 16000: N/A
16	UVC End Cap O-rings (2) 	7000: 1057691 10000: 1057707 13000: 1057714 16000: N/A
17	UVC Bulb 	7000: (9w): 1040655 10000: (11w): 1057738 13000: (13w): 1051347 16000: (18w): 1057745
18	UVC Quartz Sleeve O-rings (2)	7000: 1057752 10000: 1057752 13000: 1057752 16000: 1057752
19	UVC Quartz Sleeve Locking Nut 	7000: 1057691 10000: 1057707 13000: 1057714 16000: N/A
20	UVC Quartz Sleeve	7000: 1057752 10000: 1057752 13000: 1057752 16000: 1057752

Note:  CSM media not available for separate purchase



## GETTING TO KNOW YOUR FILTER

Model	 Over 75cm deep without fish in shade	 Over 75cm deep with fish in shade	 Under 75cm deep with fish in shade	 Over 75cm deep with fish in full sun	 Under 75cm deep with fish in full sun	 Under 75cm deep with Koi in full sun
<b>7000</b>	<b>7,000 ltrs</b> 1,540 gals	<b>3,500 ltrs</b> 770 gals	<b>2,625 ltrs</b> 577 gals	<b>2,625 ltrs</b> 577 gals	<b>1,900 ltrs</b> 418 gals	<b>984 ltrs</b> 216 gals
<b>10000</b>	<b>10,000 ltrs</b> 2,200 gals	<b>5,000 ltrs</b> 1,100 gals	<b>3,750 ltrs</b> 825 gals	<b>3,750 ltrs</b> 825 gals	<b>2,800 ltrs</b> 616 gals	<b>1,406 ltrs</b> 309 gals
<b>13000</b>	<b>13,000 ltrs</b> 2,860 gals	<b>6,500 ltrs</b> 1,430 gals	<b>4,875 ltrs</b> 1,072 gals	<b>4,875 ltrs</b> 1,072 gals	<b>3,600 ltrs</b> 792 gals	<b>1,828 ltrs</b> 402 gals
<b>16000</b>	<b>16,000 ltrs</b> 3,520 gals	<b>8,000 ltrs</b> 1,760 gals	<b>6,000 ltrs</b> 1,320 gals	<b>6,000 ltrs</b> 1,320 gals	<b>4,500 ltrs</b> 990 gals	<b>2,250 ltrs</b> 495 gals

Model	<b>W</b> Wattage & Power supply	 Max flow rate through UVC from pump	 Recommended hose size	 Dimensions w x d x h	<b>CE</b> Safety rating	 Cable length
<b>7000</b>	<b>9w (UVC)</b> <b>230v</b> <b>50Hz</b>	<b>3,500 ltrs</b> 770 gals	<b>25mm</b> <b>1"</b>	<b>40 x 42</b> <b>x 42cm</b>	Outdoor weatherproof <b>CE Approved</b>	<b>3 metres</b>
<b>10000</b>	<b>11w (UVC)</b> <b>230v</b> <b>50Hz</b>	<b>5,000 ltrs</b> 1,100 gals	<b>25mm</b> <b>1"</b>	<b>40 x 42</b> <b>x 42cm</b>	Outdoor weatherproof <b>CE Approved</b>	<b>3 metres</b>
<b>13000</b>	<b>13w (UVC)</b> <b>230v</b> <b>50Hz</b>	<b>6,500 ltrs</b> 1,430 gals	<b>32mm</b> <b>1 1/4"</b>	<b>40 x 42</b> <b>x 50cm</b>	Outdoor weatherproof <b>CE Approved</b>	<b>3 metres</b>
<b>16000</b>	<b>18w (UVC)</b> <b>230v</b> <b>50Hz</b>	<b>8,000 ltrs</b> 1,760 gals	<b>40mm</b> <b>1 1/2"</b>	<b>40 x 42</b> <b>x 50cm</b>	Outdoor weatherproof <b>CE Approved</b>	<b>3 metres</b>

# INSTALLATION

## Electrical installation

The power supply must meet the specifications on the product.

This appliance is designed to be used with either a weather-proof cable connector or connected to the mains by means of a plug and socket.

The cores in the supply cable are coloured in accordance with the following code:

**Brown = Live, Blue = Neutral, Green/Yellow = Earth**

The electrical cable is permanently connected and sealed inside the appliance

If the supply cable is damaged the appliance must not be used.

Do not use the supply cable to lift the appliance, as this may cause damage.



**WARNING:** A Residual Current Device (RCD), also known as the Residual Current Circuit Breaker (RCCB), with a tripping current not exceeding 30mA must be installed in the supply circuit. A means of disconnection from the supply having a contact separation of at least 3mm in all poles must be incorporated in the fixed wiring.

For permanent installations to the mains supply, it is necessary to conform to the regulations of the local electricity authority and this would include the use of a metal or plastic conduit to protect the cable.

Attention has been drawn to the fact that the special rules may exist concerning the installation of your pond filter (i.e. local building regulations). These filters must not be used in swimming pools, or areas where people are in contact with the water.

Always disconnect and isolate the product from the mains electricity supply whilst the equipment is being installed, repaired, maintained or handled. Consult a qualified electrician if you are in any doubt about wiring this product to the mains supply.

**Important: This appliance can be used by children aged 8 and above and persons with reduced physical, sensory or mental capabilities or lack of experience and knowledge if they have been given supervision or instruction concerning the use of the appliance in a safe way and understand the hazards involved. Children shall not play with the appliance. Cleaning and user maintenance shall not be made by children without supervision.**

# INSTALLATION

## Location of the filter

The Blagdon Clean Pond Machine should be located on a firm and level base on the ground, at least 1.2m (4') from the pond. The filter can be buried up to the bottom rim of the head unit, leaving just the UVC access, inlets & outlets, and cleaning handle exposed about the ground level. Ensure the filter outlet is at no more than a maximum of 4m head height above the lid of the filter.

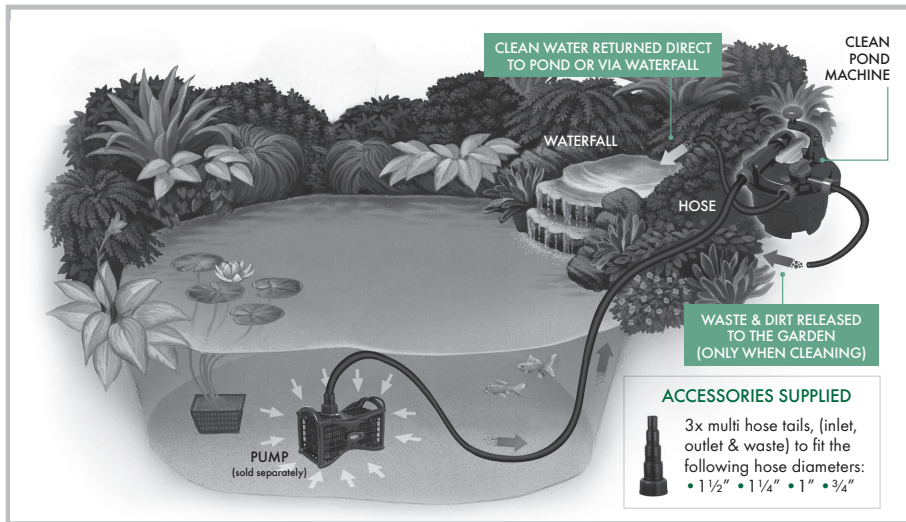

## Installation guide:

The filter can be installed above or in the ground with water returning directly to the pond, or via a waterfall, e.g:

### FILTER ABOVE GROUND

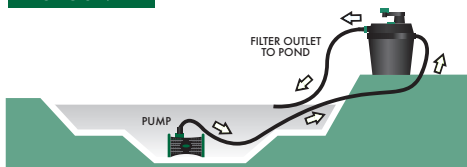

### FILTER IN THE GROUND

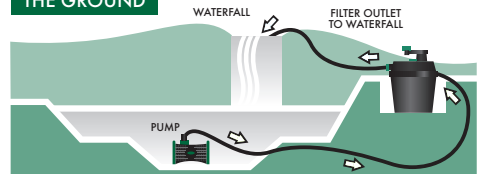



# INSTALLATION

## Connecting to your pump

The ideal flow rate for your pond is to pump the volume of the pond water through the filter every 2 hours. To calculate your pond volume: average length (m) x average width (m) x average depth (m) x 1000 = pond volume in Litres.

To calculate your pump's flow rate, fill a container from the filter outlet hose at the pond side. Time how long this takes in seconds, e.g. a 10 Litre bucket takes 12 seconds to fill. Divide 3600 (the number of seconds in an hour) by the time taken to fill the bucket, e.g. 12 seconds. Then multiply by the volume of the container, e.g. 10 Litres. Therefore:  $3600/12 = 300$ ,  $300 \times 10 = 3000\text{L/H}$  flow rate.

To increase flow, you may require a larger pump. If the flow rate is too high, use an inline valve to reduce it (or use the digital control of a Blagdon Amphibious IQ pump).

The purpose of the pump is to transfer dirty water from the pond to the filter cannister. Placing the pump at the opposite end to the filter outlet will provide the best results. Pumps without foam pre-filters will allow for optimum filter performance.

**IMPORTANT:** Do not exceed the maximum stated flow rate through the UVC filter - see technical specifications table on page 4 for reference.

## Connecting the inlet/outlet hoses

- Always secure the hose with a jubilee clip.
- Warming the hose in a bucket of warm water can aid fitting.
- Always ensure the smaller diameter hose tails are cut off and removed to prevent poor UVC performance and flow rate from the outlet.
- Use the shortest possible lengths of hose, in order to minimise flow restrictions.
- Avoid folds and kinks in the hose, which will reduce flow and UVC performance.

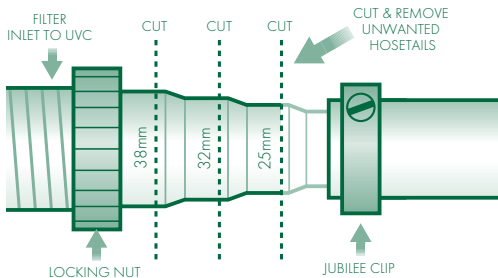

### IMPORTANT:

The outlet hose should be smooth bore (not corrugated) pipe installed over as short a distance as possible, with no kinks or bends. We recommend that a smooth bore clear hose, or smooth bore heavy duty black hose are used.

# INSTALLATION

## UVC bulbs & quartz sleeve maintenance

The UVC bulb must be replaced yearly – it is recommended that the bulb is replaced in the spring or early summer, in order to provide the maximum performance during the most problematic period of the year for green water.

The quartz sleeve can become coated in lime scale build up in hard water areas. This should be carefully removed from the quartz sleeve with a soft cloth.

A wet test must be carried out after maintenance to ensure there are no leaks before the UVC is reconnected.

1. Undo the four screws on the UVC electronics cover cap
2. Unscrew the UVC electronics cover cap.
3. Inspect the UVC cap and quartz sleeve for water leaks.
4. If there are no signs of leakage reverse the procedure ensuring that the cover O-ring is in place.

### IMPORTANT:

A wet test of the filter under operating conditions must be carried out before the UVC or power supply are installed.

Connect the filter to the pump following all installation instructions, check for leaks after 24 hours.

The unit is protected by a micro-switch, which prevents the UVC light from illuminating when the cover is removed.

In order to check that the UVC lamp is operating correctly, check the indicator window above the cable inlet gland on the UVC electronics cover cap whilst the UVC is installed into the filter. This operation is best carried out at dusk, as UVC lamps emit a dim blue light which can be difficult to see in daylight.

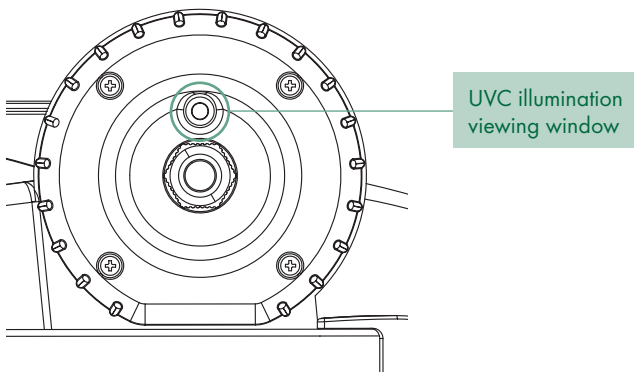

# INSTALLATION

## Testing/replacing the UVC lamp

### IMPORTANT:

Ensure the mains power supply is switched off and the power isolated before removing the UVC cover.



### WARNING:

Dangerous Ultra Violet radiation. The rays from the UVC lamp are harmful to eyes and skin. ALWAYS turn off the UVC electrical supply before any maintenance.

1. Undo the four screws on the UVC electronics cover cap
2. Pull out the UVC electronics cover cap.
3. Unscrew the Quartz sleeve lock nut.
4. Remove the old bulb, and replace for new.
5. Complete steps 1-4 in the reverse order to reconstruct the unit - ensuring all O-rings are correctly positioned.

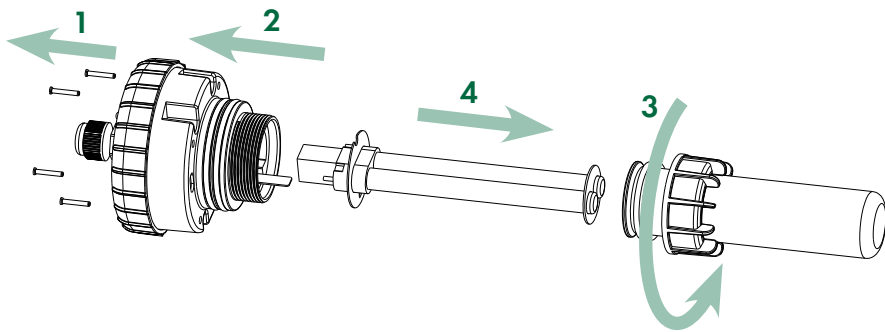

### IMPORTANT:

If there has been any damage to the unit, please return to the point of purchase for inspection. This check should be performed whenever the UVC bulb or quartz sleeve is changed.

## MAINTENANCE & CLEANING

Your Blagdon Clean Pond Machine has been designed to need a minimum of maintenance. It will work at it's best with some simple, monthly routine maintenance.

If the filter is installed on an established pond, the regularity of cleaning may be increased for a period until any back log of accumulated pond waste has been removed.

### Normal Running

For excellent filtration, the filter should be operated 24 hours a day, all year round.

1. Check that all seals and connections are not leaking.
2. Ensure the valve is turned to the outlet returning to your pond or waterfall.

### Routine Maintenance

Once established, it is recommended that your filter should be backwashed and cleaned once a month.

It may require more frequent cleaning when:

- The flow has visibly reduced.
- The water in the pond appears dirty.

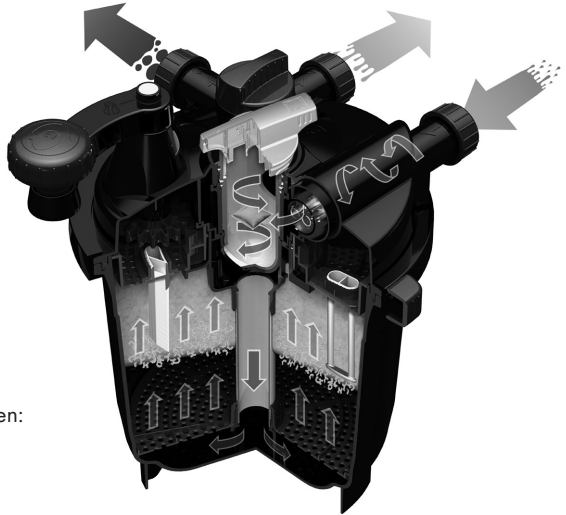

**NOTE:** The cleaning procedure uses water pumped from the pond, meaning during cleaning the water level in your pond will drop. After cleaning you should refill the pond using water which has been dechlorinated with a product such as Blagdon 'Clean Pond Pods' or Blagdon 'Fresh Start'.

**IMPORTANT:** If the filter has not been cleaned for more than a month, or if the flow rate from the outlet has dropped by 50% or more - after turning the flow diverter valve to waste, turn the pump off before attempting to turn the cleaning handle.

After one full rotation the pump can be turned back on to flush out the waste released, and the filter can be cleaned as per the usual instructions.

## MAINTENANCE & CLEANING

To clean your Blagdon Clean Pond Machine, follow these simple steps:

- 1** Turn outlet valve to waste.

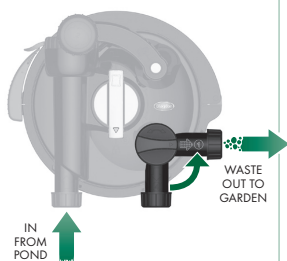

- 2** Rotate handle to clean.

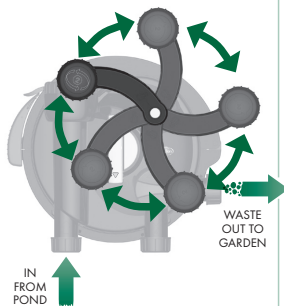

- 3** Rotate Pod dosing chamber cap & remove. Insert Clean Pond Pod.

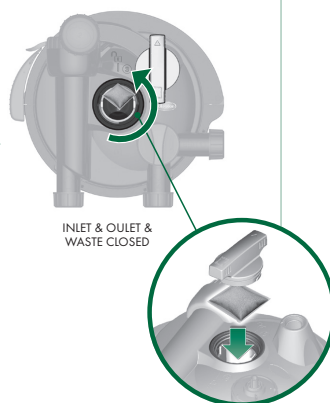

- 4** Turn outlet valve to pond.

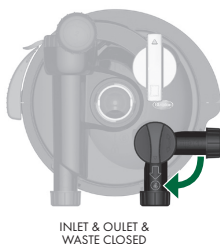

- 5** Replace and rotate dosing chamber cap.

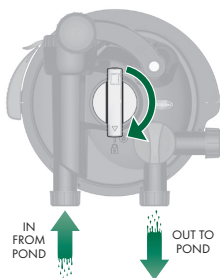

**NOTE:** A maximum of 10 Clean Pond Pods can be fitted into the dosing chamber at any one time, this is sufficient for a pond with a volume of 5000L. If a higher amount is needed, the dose should be split in half and dosed over subsequent days to allow the pods time to dissolve.

If Clean Pond Pods are being dosed at the same time as a filter clean, return the flow back to the pond before closing the dosing chamber lid – else the action of cleaning will wash the contents of the pod away as waste.

**NOTE:** If you are not dosing Clean Pond Pods or you are cleaning the filter as part of a water change you do not need to remove the dosing chamber cap, simply return the flow diverter valve back to the filter outlet once the water runs clear or you have drained the desired amount of water from the pond.

# MAINTENANCE & CLEANING

## Winter Storage

The filter can be run year round as long as the pump flow is maintained, this is the best option. Alternatively, in winter, the filter can be switched off. If the filter is to be switched off during the winter it should be fully drained of water prior to being stored in a frost-free location, such as a shed or garage, until spring.

## Annual Maintenance

### Check for wear

Once a year it is recommended to dismantle your Blagdon Clean Pond Machine and examine the parts for wear or damage – replacing parts showing any signs of wear or damage.

### Replacing filter media

Due to the material and method used in cleaning the filter media contained in the Blagdon Clean Pond Machine, it should never need replacing, as even if it is clogged solid, and unable to be cleaned using the handle, it is possible to clean it by removing it from the filter into a bucket of water taken from the pond.

#### **IMPORTANT:**

If the head unit is removed, keep it upright. This will prevent any of the filtration media stuck on the cleaning blades and plate from falling and getting stuck in the cleaning mechanism.

When returning the head unit to the filter be sure to carefully remove some water from the cannister to lower the level of the media below that of the central downpipe – retrieve any media which has entered this pipe and return it to the main filter body.

# MAINTENANCE & CLEANING

## Annual Maintenance

### Disassembling/reassembling your Clean Pond Machine

We would recommend to clean the bottom grill annually to maintain the performance of the filter, to clean this the following instructions should be followed:

1. Turn off the pump.
2. Undo and remove the lid clasp, lift off the filter head unit.
3. Carefully remove all of the CHI media to a clean bucket and drain the filter cannister of water.
4. Unscrew the central locking nut and remove the downpipe.
5. Lift the bottom grill out from the bottom of the filter and rinse in clean, fresh water.
6. Return the grill to its position in the bottom of the cannister (note the locating notches and fins), reinstall the downpipe and locking nut to lock it in position.
7. Cover the hole of the downpipe and carefully return the CHI media to the filter cannister, once it's all in uncover the downpipe.
8. Reinstall the filter head unit and lid clasp – reattach any hosetails and turn the pump back on. (ensure the flow diverter valve is initially positioned to waste to flush out any fish waste which has been dislodged from the media in the process.)

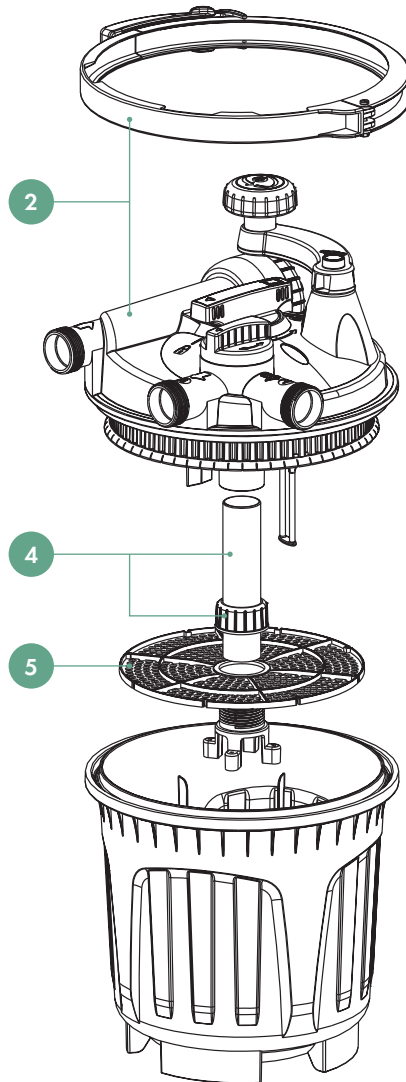

# TROUBLESHOOTING

## Filter Leaks

- Check that the inlet and outlet nuts and O-rings have been correctly assembled and that they are hand tight.
- PTFE tape may be needed to give a water tight seal, and should be applied to the thread of the inlet and outlet hose tails.
- Ensure the filter head gasket is in the correct position, and is free from any detritus.
- Ensure that the hoses are secured to the inlet and outlet hose tails with a Jubilee Clip.
- Ensure that the filter is installed on a flat level base.

---

## Cloudy/Brown Water

- Check that you have correctly calculated the pond volume, pond depth and the ponds level of direct sunlight. Check this information against the pond sizing table on page 4. You may require a larger Clean Pond Machine model.
- Adding shade to the pond by introducing lilies or floating plants to the water surface will help to reduce pond sludge. Planting the pond with marginal plants will also help create a balance. New ponds may require some time to establish and create a healthy balance.
- The filter is not being supplied with water 24 hours a day. Do not turn off the pump feeding the filter with water – continuous running is required for the beneficial bacteria within the filter to break down fish waste.
- The filter media is insufficiently blocked – allow the Clean Pond Machine media time to clog, as the media clogs it will trap finer and finer waste.
- The water is extremely dirty – physically remove pond waste and leaves, carry out a partial water change.

---

## UVC Leaks

- Check that the UVC O-rings are all in the correct position.
- Check for damage to the Quartz sleeve.
- Ensure the UVC electronics cap is tightened sufficiently to make the watertight seal.

---

## Low/No flow from filter

- Check that the pump is running. Check the mains power supply.
- Ensure all pipework is fully connected to the pump and filter.
- Check for blockages in the pipework.
- Clean the filter – the Clean Pond Machine media may have become too blocked by pond waste.



# TROUBLESHOOTING

## Green Water

- Perform a settlement test to ensure that there is no sediment suspended in the water – if there is follow the brown/cloudy water troubleshooting guide.

### PERFORMING A SETTLEMENT TEST:

Take a glass of water from the pond and allow to settle for a few hours. If when the glass is stirred a small layer of settled waste can be seen at the base. This indicates that you have brown/cloudy water and that, if you have a UVC, it is working correctly. If there is no settlement it indicates that you have green water and that the UVC is not working correctly.

- At dusk check the UVC light is illuminated using the viewing window on the UVC electronics cap.

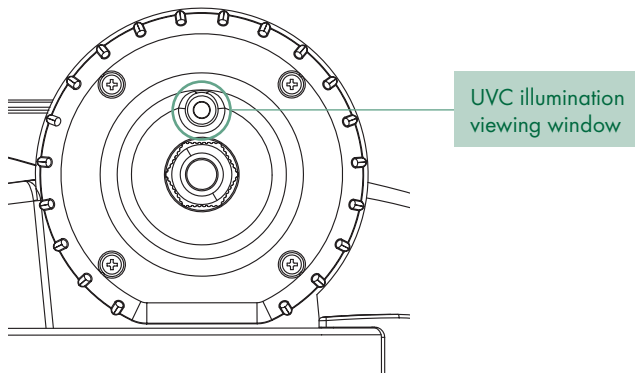

- Check the age of the UVC bulb. As UVC bulbs age the light output deteriorates, if the bulb is over 6 months old, the output may not be strong enough to have an effect on the algae causing green water – change the bulb.
- The UVC may be working effectively, but the filter media is too clean so is unable to remove the fine coagulated waste – treat the pond with a clearing product, such as Blagdon Clear Pond, this will clump the particles together to make them larger, and therefore easier to remove from the water passing through the filter.

## IMPORTANT

### FAULTS - PROBLEMS PROCEDURE

Before returning your Blagdon air filter to your dealer or contacting our Consumer Advice Department, please carry out the following steps. These will solve most problems quickly and easily:

1. Ensure electrical procedure has been followed fully. Check fuses and any cable connectors or switchboxes.
2. Follow the maintenance steps from pages 10-13, follow the troubleshooting options from pages 14-15.
3. Return filter to point of purchase for inspection and advice (proof of purchase may be required)

### CONSUMER ADVICE CONTACT DETAILS:

Interpet (Blagdon) Consumer Advice Department Vincent Lane, Dorking, Surrey, RH4 3YX  
E-mail: [customercare@interpet.co.uk](mailto:customercare@interpet.co.uk)

## GUARANTEE

This product is guaranteed against defects in material and workmanship for 3 years from the date of purchase, under normal usage. **The guarantee DOES NOT APPLY in case of improper use, negligence, lack of maintenance or accidental damage to the filter.**

If the filter fails due to a manufacturing fault within this period it will be either repaired or replaced free of charge. Liability is limited to replacement of the faulty product only, no other costs will be reimbursed.

This guarantee is not transferable and does not affect your statutory rights. This guarantee does not confer any rights other than those expressly set out above. Excludes the UVC which may need annual replacement, which may become worn over time. If any parts need replacing, spares are available from your local retailer.

## ENVIRONMENT FRIENDLY DISPOSAL

You can help to protect the environment, please remember to respect local regulations, hand in non-working electrical equipment to an appropriate waste disposal centre.



CE

RoHS





**INNOVATIVE**



**DESIGN**

Interpet, Vincent Lane,  
Dorking, Surrey, RH4 3YX

[www.interpet.co.uk](http://www.interpet.co.uk)  
[www.blagdonwatergardening.co.uk](http://www.blagdonwatergardening.co.uk)

Leaflet Code: MB 9/12/19

Established over 50 years ago, Blagdon are committed to producing a comprehensive range of high quality and easy to use water gardening equipment. We have an on-going programme of research and development that ensures excellent product performance and value for money for our customers. Our products are brought together with half a century of expertise and knowledge so you can be assured of a successful and creative water garden.