



# Pond Oxygenator

1800 / 2400 / 3600

[www.blagdonwatergardening.co.uk](http://www.blagdonwatergardening.co.uk)  
[www.interpet.co.uk](http://www.interpet.co.uk)



**Congratulations on buying a Blagdon Pond Oxygenator air pump.** The Pond Oxygenator range has been specifically designed for water gardening applications. Pond aeration is an essential part of a successful pond. The Pond Oxygenator air pumps are able to run multiple air stones at one time allowing you to create a healthy, oxygen rich environment which will benefit your fish and biological filter bacteria

#### **BENEFITS OF POND AERATION:**

Fish and other pond life require oxygen-rich water in order to remain healthy. Filter bacteria essential for the breakdown of highly toxic ammonia and nitrite, also require oxygen to flourish and keep the pond free from the build up of toxic waste. Use of a Blagdon Pond Oxygenator will dramatically increase the level of oxygen in the pond and reduce carbon dioxide levels, thus aiding in preventing the pond from stagnating, by injecting air into the water.

Additionally, by placing the air stones directly into the filter chambers beneficial bacteria, essential to the well being of a pond will be encouraged to grow. This will help to improve filter efficiency and fish health.



#### **AERATION IN THE POND IS ESPECIALLY IMPORTANT DURING:**

- Warm weather: when water holds less dissolved oxygen.
- At night: when plants stop producing oxygen and begin to use it up.
- Winter: can be used to keep an area ice-free, preventing the build up of toxic gases.
- Treatment: many treatments deplete oxygen levels.

**IMPORTANT:** PLEASE ATTACH PROOF OF PURCHASE TO THIS MANUAL AND KEEP IN A SAFE PLACE.

# CONTENTS

Getting to know your Pond Oxygenator air pump.....	2
Exploded diagrams / Technical Specification / Parts list.....	2-3
<b>Installation</b> .....	<b>4</b>
Electrical installation.....	4
Location .....	5
Connecting air line and air stones.....	5
<b>Maintenance</b> .....	<b>6</b>
Changing the replaceable parts.....	6
Replacing the flapper valves.....	7
Replacing the diaphragm.....	8
<b>Troubleshooting</b> .....	<b>9</b>
Troubleshooting and maximising performance.....	9
<b>Faults/Problems Procedure</b> .....	<b>10</b>
Customer Care contact details.....	10
Returning faulty Pond Oxygenators.....	10
<b>Guarantee</b> .....	<b>10</b>

			
POND SIZE	MODEL	WITH FISH	WITH KOI
LARGE POND	<b>1800</b>	10,000 LITRES 2,200 GALLONS	5,000 LITRES 1,100 GALLONS
LARGE+ POND	<b>2400</b>	15,000 LITRES 3,300 GALLONS	7,500 LITRES 1,650 GALLONS
EXTRA LARGE POND	<b>3600</b>	22,500 LITRES 4,839 GALLONS	11,000 LITRES 2,420 GALLONS

# GETTING TO KNOW YOUR POND OXYGENATOR

## Pond Oxygenator Single Parts Diagram:

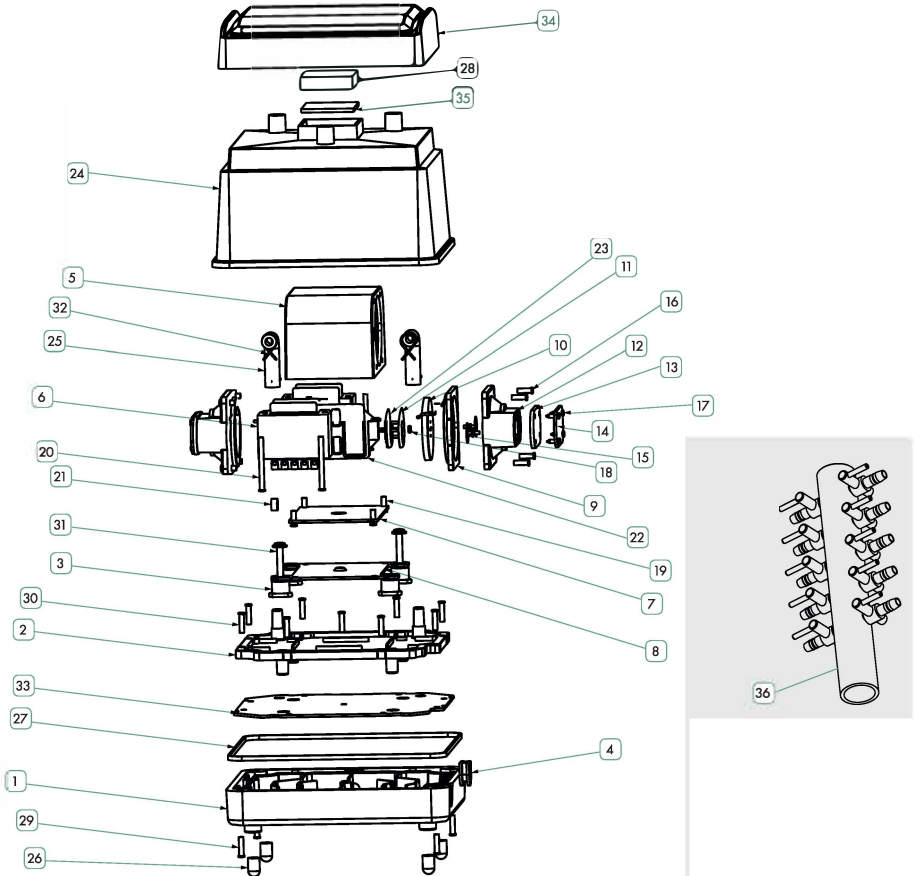

Pond Oxygenator model	Cable length	Power supply required	Wattage	Maximum air flow	Maximum pumping depth	Maximum pressure	Number of air outlets
1800	5m (16'4")	230v/ 50Hz	16 Watts	1800 L/H	2.2m (7'2")	0.022MPa	6
2400	5m (16'4")	230v/ 50Hz	20 Watts	2400 L/H	3m (9'10")	0.028MPa	10
3600	5m (16'4")	230v/ 50Hz	32 Watts	3600 L/H	3m (9'10")	0.030MPa	20

# GETTING TO KNOW YOUR POND OXYGENATOR

Part Number	Part Description
1	Pump base
2	Motor mounting plate
3	Rubber dampener
4	Cable gland
5	Motor cover
6	Magnet coil
7	Motor foam seal
8	Motor base plate
9	Diaphragm mount
10	Diaphragm*
11	Outer diaphragm grip
12	Flapper valve chamber*
13	Flapper valve chamber rubber seal*
14	Flapper valve chamber metal seal*
15	Flapper valves*
16	Flapper valve chamber bolts
17	Flapper valve chamber seal screws
18	Diaphragm grip nut
19	Motor base nuts
20	Magnet coil bolts
21	Motor cable gland
22	Magnet bracket
23	Inside diaphragm grip
24	Pump case
25	Internal rubber elbow*
26	Rubber feet
27	Pump rubber gasket*
28	Coarse foam*
29	Pump base bolt
30	Mounting plate bolts
31	Motor base mounting bolts
32	Metal clasp
33	Mounting plate rubber seal
34	Pump lid
35	Polymer wool pad*

All parts marked by an asterisk (\*) are available in the Annual Service Kit:

Also available: Part 36 (Metal outlet with valves)

Pump Model	Annual Service kit order code
1800	1057356
2400	1057363
3600	1057370

Metal outlet with valves	Order code
10 - Way	1057387
18 - Way	1057394

# INSTALLATION

## Electrical installation



The power supply must meet the specifications on the product.

The air pump is designed to be used with either a weather-proof cable connector or connected to the mains by means of a plug and socket.

The cores in the supply cable are coloured in accordance with the following code:

**Brown = Live, Blue = Neutral, Green/Yellow = Earth**

The electrical cable is permanently connected inside the air pump body.

If the supply cable is damaged the air pump must not be used.

Do not use the supply cable to lift the air pump, as this may cause damage.



**WARNING** - A Residual Current Device (RCD), also known as the Residual Current Circuit Breaker (RCCB), with a tripping current not exceeding 30mA must be installed in the supply circuit. A means of disconnection from the supply having a contact separation of at least 3mm in all poles must be incorporated in the fixed wiring.

For permanent installations to the mains supply, it is necessary to conform to the regulations of the local electricity authority and this would include the use of a metal or plastic conduit to protect the cable.

Attention has been drawn to the fact that the special rules may exist concerning the installation of your pond air pump (i.e. local building regulations). These air pumps must not be used in swimming pools, or areas where people are in contact with the water.

Always disconnect and isolate the product from the mains electricity supply whilst the equipment is being installed, repaired, maintained or handled. Consult a qualified electrician if you are in any doubt about wiring this product to the mains supply.



**WARNING** - The air pumps must not be submerged in the pond, they are for external installation only.

# INSTALLATION

## Location

The Pond Oxygenator Pumps have been designed to be weather-proof, so they are able to be installed in most locations around the garden, or in a shed or garage, close to your chosen power supply. Ensure that the air pump is installed above the pond water level to avoid back siphoning of pond water into the air pump in the event of a mains power failure. Alternatively, if the air pump can only be installed below the pond level install Aqua Air Check Valves into each piece of air line. The air pump should be located on a firm surface which will not vibrate and act as a sounding board, a concrete floor or paving slab would be ideal.

Position the air pump in a clean and dust free environment. Excessive dirt will block the air filters, reducing the air pumps performance and increase the speed of wear on replaceable parts.

**IMPORTANT** - The air pump must be stood the correct way up - with all four rubber feet touching the surface on which it is installed. This will ensure the maximum protection from adverse weather conditions. Water ingress will cause damage, and void the warranty.

## Connecting the air line and air stones

Your Pond Oxygenator has been designed to run continuously and ideally unrestricted. This will maintain maximum performance and the best possible life span for all replaceable parts e.g. diaphragms and flapper valves.

Ideally all outlets should have an air line and air stone connected, this will give your pond maximum aeration and ensure that damaging back pressure is kept to a minimum. Over time, air stones will become blocked leading to a reduction in air pump performance, therefore it is advised to replace the air stones every twelve months as a minimum, or more frequently depending on the cleanliness of the air pumps environment.

Attach one end of the air line to the metal outlet on the Pond Oxygenator, attach the air stone to the other end of the air line. Then simply place the air stone into your pond or filter, and turn on the air pump.

The air stones should be positioned to provide maximum aeration and circulation in the pond. (Note: for use in winter, the air stones should be placed no lower than 30cm from the bottom of the pond, this will ensure the warmer lower water regions remain undisturbed.)

# MAINTENANCE

**TIP** - If you plan on not using all of the outlets, loop a piece of airline between a pair of unused nozzles.

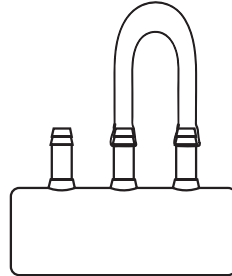

## Changing replaceable parts

The Pond Oxygenator air pump range has been designed to run reliably for many years if correctly maintained. Like other air pumps, they contain perishable rubber parts which have a limited life span. These parts have been designed so they can be easily replaced, therefore maintaining the performance of the air and extending its lifespan.

**Important:** As a rule we would recommend to replace the diaphragms, flapper valves and foam filters annually. This will ensure that the Pond Oxygenator is giving the optimal performance.

**Important:** Ensure the air pump is isolated from the mains power supply before performing any maintenance.

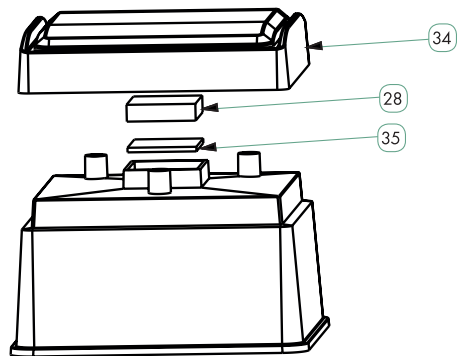

### Tools needed:

- Medium sized Phillips head screwdriver
- A pair of pliers

### Replacing the air intake foams:

1. Lift off the pump lid (part 34).
2. Remove and replace the air filter foam and polymer wool pad (parts 28 and 35).
3. Return the lid to the correct position on the top of the pump.



# MAINTENANCE

## Replacing the flapper valves:

1. Unscrew and remove the four base screws from the underside of the air pump and lift off the pump case.
2. Detach the rubber elbows from the flapper valve chamber and unscrew the four flapper valve chamber screws.
3. Remove the flapper valve metal and rubber seals (parts 13 & 14).
4. Remove the rest of the flapper valve chamber and replace for new.
5. Reattach the rubber and metal flapper valve chamber seals, and reattach the assembly to the pump.
6. Return the pump case to its correct position and reinsert the base screws.

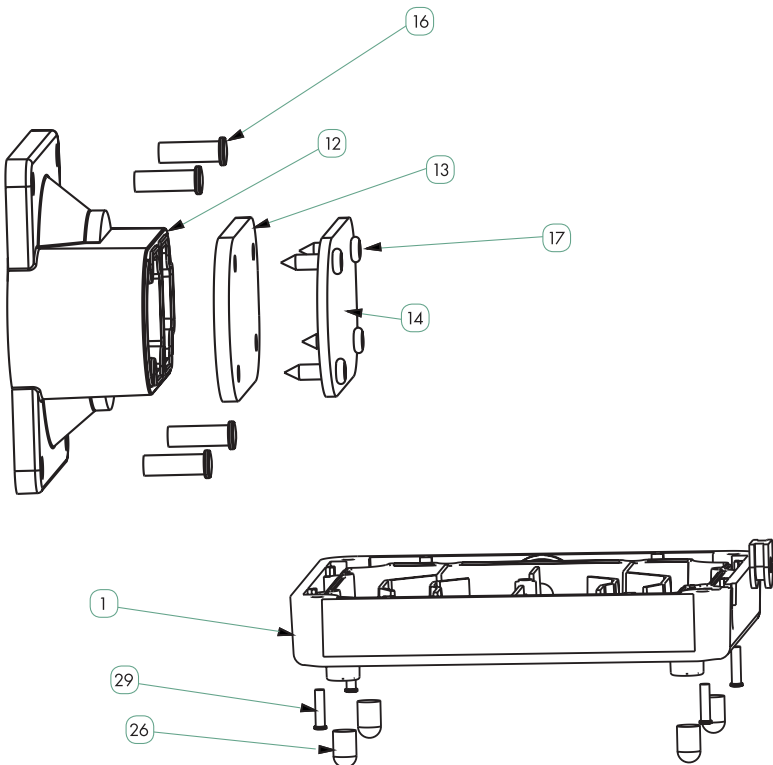

# MAINTENANCE

## Replacing the diaphragm:

1. Follow steps 1-4 for replacing the flapper valves, putting the flapper valve chamber to one side rather than replacing it.
2. Using a pair of pliers, undo the nut holding the diaphragm in place and remove the washer. Remove the diaphragm assembly (consisting of parts 9, 10, 11 & 23) from the pump body.

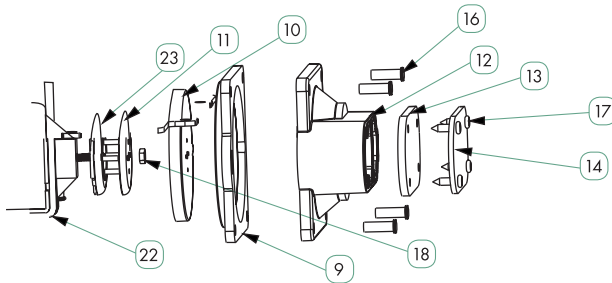

3. Carefully remove the plastic diaphragm grips (parts 11 & 23), and remove the rubber diaphragm from the plastic frame.
4. Insert new rubber diaphragm, ensure it is fully clipped into the groove provided and that the tab on the outside edge fits into the cut out on the plastic frame.
5. Reinsert the inside diaphragm grip lining the pins up with the holes on the diaphragm. Ensure the grip is installed in the correct position to allow it to fit correctly back onto the magnet mount in the pump motor. See the images below for the correct positioning.

### 1. Correct

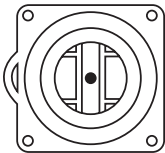

### 2. Incorrect

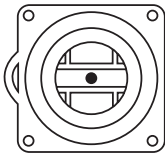

6. Relocate the outside diaphragm grip on the opposite side of the diaphragm, lining the holes up with the pins from the inside grip.
7. Return the diaphragm assembly to the pump body, lining the thread from the magnet holder with the central hole on the diaphragm, and the tab on the inside of the plastic frame with the cut out on the pump body.
8. Reattach the washer and nut to the thread of the magnet holder.
9. Reattach the flapper valve chamber over the diaphragm.

# TROUBLESHOOTING

## Low air output/noisy operation

- Is the pump on a sounding board, such as a wooden shed floor. If so, place the pump on a patio slab, this will help to reduce the noise caused by the vibration of the pump.
- Using silicone airline will help to reduce the noise generated further
- Are the air line check valves blocked or are the air lines kinked.
- Placing air stones at a greater depth increases the back pressure on the pump, as it must work harder to pump deeper it may become noisier. Relocate the air stones to a shallower area to help reduce the noise.
- Check and replace old, blocked and dirty air stones.
- Replace blocked or dirty intake foam pads.
- Replace damaged or worn flapper valves.
- Check diaphragms for wear and tear, replace as necessary.
- Excessive noise and wear will occur if the pump is not operated in a dust/dirt free environment – as this will lead to the intake foam pads to become blocked quicker.

## No air output/pump stopped

- Check the power supply is on.
- Check fuses and wiring (see electrical installation).
- If the pump is situated below pond level, and has been installed without check valves, water may have siphoned back into the motor.
- All flapper valves may have failed – check and replace as necessary.
- Both diaphragms may have failed – check and replace as necessary.
- Intake foams may be severely blocked – check and replace as necessary.

*If none of the above resolves the fault encountered, contact our Customer Care department – see Faults and Problems procedure.*

## IMPORTANT

### FAULTS - PROBLEMS PROCEDURE

Before returning your Blagdon air pump to your dealer or contacting our Consumer Advice Department, please carry out the following steps. These will solve most problems quickly and easily:

1. Ensure electrical procedure has been followed fully. Check fuses and any cable connectors or switchboxes.
2. Follow the maintenance steps from pages 6-8, follow the troubleshooting options from page 9
3. Return pump to point of purchase for inspection and advice (proof of purchase may be required)

### CONSUMER ADVICE CONTACT DETAILS:

Interpet (Blagdon) Consumer Advice Department Vincent Lane, Dorking, Surrey, RH4 3YX  
E-mail: [customercare@interpet.co.uk](mailto:customercare@interpet.co.uk)

## GUARANTEE

This product is guaranteed against defects in material and workmanship for 3 years from the date of purchase, under normal usage. **The guarantee DOES NOT APPLY in case of improper use**, negligence, lack of maintenance or accidental damage to the pump.

If the air pump fails due to a manufacturing fault within this period it will be either repaired or replaced free of charge. Liability is limited to replacement of the faulty product only, no other costs will be reimbursed.

This guarantee is not transferable and does not affect your statutory rights. This guarantee does not confer any rights other than those expressly set out above. Excludes the diaphragm and flapper valves, which may become worn over time. If any parts need replacing, spares are available from your local retailer.

## ENVIRONMENT FRIENDLY DISPOSAL



You can help to protect the environment, please remember to respect local regulations, hand in non-working electrical equipment to an appropriate waste disposal centre.



**RoHS**

INNOVATIVE



DESIGN

Interpet, Vincent Lane,  
Dorking, Surrey, RH4 3YX

[www.interpet.co.uk](http://www.interpet.co.uk)  
[www.blagdonwatergardening.co.uk](http://www.blagdonwatergardening.co.uk)

Leaflet Code: 26/10/18 MB

Established over 50 years ago, Blagdon are committed to producing a comprehensive range of high quality and easy to use water gardening equipment. We have an on-going programme of research and development that ensures excellent product performance and value for money for our customers. Our products are brought together with half a century of expertise and knowledge so you can be assured of a successful and creative water garden.